

# PROTECT FROM CONTAMINANTS WITH AUSTRALIAN-MADE INNOVATION

## SORBSEAL® HYBRID GEOSYNTHETIC CLAY LINERS

### INSTALLATION GUIDE

Sorbseal® is an Australian made hybrid Geosynthetic Clay Liner (hGCL) which works as a barrier to liquids and helps trap a wide range of contaminants, including potentially dangerous Per- and Polyfluoroalkyl Substances (PFAS), preventing them from entering the surrounding environment.

Like Elcoseal GCL, Sorbseal hGCL consists of premium grade sodium bentonite powder, which acts as the swelling and sealing component. However, it differs in that in addition it also includes premium grade activated carbon, which acts as the barrier for dangerous chemicals such as PFAS. Both the bentonite and activated carbon are embedded and sandwiched between two or more geotextiles. The composite is then needle-punched through all layers and thermally-locked developing high connection strength. Thus, Sorbseal is a shear strength transmitting hGCL.

Sorbseal is fast and easy to install, and the performance is dependent on the quality of its installation. It is the installer's responsibility to follow these guidelines and the project specifications and drawings whenever possible. It is the engineer's and owner's responsibility to provide construction quality assurance (CQA) for the installation to ensure that the installation has been executed properly. Variance from this guideline is at the engineer's discretion.

### RECOMMENDED FURTHER READING

- ASTM D 5888 Standard Guide for Storage & Handling of GCLs
- ASTM D 6102 Standard Guide for Installation of GCLs
- ASTM D 5889 Standard Practice for Quality Control of GCLs
- ASTM D 6072 Standard Guide for Obtaining Samples of GCLs

### BEFORE YOU BEGIN

Prior to delivery of Sorbseal on-site, ensure the project team has:

- Read these guidelines
- Raised any questions not answered by these guidelines with Geofabrics
- Read the Sorbseal Safety Data Sheet, Bentonite Material Safety Datasheet and Activated Carbon Material Safety Datasheet (available on the Geofabrics website)
- All the required equipment to unload, store and install Sorbseal on site
- All the required PPE for safe handling and installation of Sorbseal

### PERSONAL PROTECTIVE EQUIPMENT

The use of respiratory, eye, hand and body protection are recommended when handling Sorbseal Hybrid Geosynthetic Clay Liners. Please refer to the Sorbseal Safety Data Sheet for more information prior to any commencement of work. Sorbseal contains powdered sodium bentonite which contains quartz/cristobalite which is classified as hazardous according to the Globally Harmonised System of Classification and Labelling of Chemicals (GHS).



A respirator with a removable dust mask should be used



Safety glasses with side shields should be worn



GHS Classified as hazardous



Wear suitable protective workwear. Overalls are recommended.



Wear gloves of impervious material

# PACKAGING, TRANSPORTATION, UNLOADING & STORAGE

## Packaging

Sorbseal rolls are packed in moisture tight plastic wrapping. The standard roll dimensions and weights are listed in Table 1 below.

Every Sorbseal roll has a unique roll number on the wrapping label and on the panel itself. This information allows for matching of manufacturing quality assurance (MQA) records.

**Table 1: Sorbseal Roll Dimensions & Freight Capacities**

	S1000	S2000
Width(m)	4.7	4.7
Length (m)	4.5	45
Diameter (m)	~0.80	~0.80
Roll Mass (kg)	~1400	~1500
Rolls per B Double	25	22
Rolls per 20ft Container	11	10
Rolls per 40ft Container	25	22

**!** After transportation and unloading the plastic wrapping should be checked. Minor damage should be repaired with weather-resistant adhesive tape. Wrapping should only be removed immediately before use.

## Unloading

A flat, hard, dry and free draining surface must be provided for unloading and storage. Offloading on site will require heavy equipment: an excavator (tracked or wheeled); front-end loader; or a forklift. Heavy equipment must be correctly rated for the expected load (see Table 1 on the previous page). Rolls may be offloaded using:

**A** A Spreader Bar with steel tube insert through the core of the rolls. Refer to the Sorbseal Spreader Bar Safe Usage Guideline from the Geofabrics website for detailed information; OR

**B** A 'carpet prong', rated to 1,500 kg and matched to the forklift, protruding from the front end of the forklift (>4.5 tonne) or other equipment. The prong should be at least  $\frac{3}{4}$  the length of the Sorbseal core and also must be capable of supporting the full weight of Sorbseal without significant bending; OR

**C** The two slings provided by Geofabrics (upon request) wrapped around the Sorbseal roll at third ( $\frac{1}{3}$ ) points along the roll, fixed to an excavator arm or a front-end loader. Slings should not be used for general lifting and transportation around the site. If excessive deformation or bending of the roll occurs the integrity of the geocomposite may be affected. A steel tube or similar reinforcement can be inserted into the core of the roll to prevent excessive deformation across the roll during handling.

**!** Sorbseal rolls should not be exposed to moisture prior to installation. Damaged wrappers should immediately be repaired with weather resistant tape. Wrapping should only be removed from Sorbseal rolls immediately prior to installation.

## Storage

Sorbseal rolls should be stored in their original, unopened packaging in a location away from construction traffic but sufficiently close to the active work area to minimise handling.

The designated storage area should be level, dry, well-drained, stable, and should protect the product from:

- Precipitation
- Chemicals
- Standing water
- Excessive heat
- Ultraviolet radiation
- Vandalism and animals

Sorbseal rolls should always be stored lying flat, continuously supported, and should never be stored standing on one end. Enclosed indoor storage such as shipping containers or a warehouse environment is preferred if Sorbseal is to be stored for long periods.

Sorbseal rolls should not be exposed to moisture prior to installation. Damaged wrappers should immediately be repaired with weather resistant tape. Wrapping should only be removed from Sorbseal rolls immediately prior to installation.

## INSTALLATION

### What you'll need on site

Prior to commencement of installation the following equipment will be required:

- Excavator (tracked or wheeled) or a front-end loader. Equipment should be rated for the expected load. Please see Table 1 on page 2 of this document for roll masses;
- Spreader bar/loading frame;
- HP Paste;
- Trowel;
- Carpet knife, safety knife or Bosch Cutter
- Felt pens or chalk;
- Measuring tape;
- Broom;
- PPE including dust mask, goggles, gloves and protective workwear.

### Weather conditions for installation

Light rainfall (defined as <5mm/hour intensity) should not affect the installation of Sorbseal provided deployed panels are covered and confined by 300 mm of cover soil (or equivalent) within 2 hours of first exposure to the light rain. Heavy direct raindrop impact should be avoided. The Sorbseal panels can be covered during heavy rainfall events with a tarpaulin or plastic sheet if there is not enough time to complete soil cover placement.

Avoid placing Sorbseal in areas where water is ponding unless panels can be confined immediately (with 300 mm cover soil or equivalent).

**!** *Sorbseal rolls should not be exposed to moisture prior to installation. During installation Sorbseal panels should be covered with a tarpaulin or plastic sheet during heavy rain events.*

### Subgrade preparation

The preparation of the subgrade before placement of any lining material is critical to the system's performance. The surface(s) upon which Sorbseal is to be laid should be suitable for the intended application and function.

Sorbseal will generally be placed on either an earthen e.g. compacted clay, or geosynthetic e.g. geotextile or geocomposite) subgrade.

### Earthen Subgrades

The surface upon which Sorbseal will be deployed should conform to the following:

- The subgrade should be firm and unyielding (typically compacted to >90% density), without abrupt elevation changes, and be proof rolled with a smooth drum roller immediately prior to deployment of the Sorbseal panels. The subgrade should not be disturbed or rutted by the equipment deploying the rolls or other traffic. No foreign matter or stones loose on the surface or penetrating out of the subgrade >10 mm should be allowed. The engineer's approval of the subgrade needs to be obtained immediately prior to roll deployment;
- In applications where Sorbseal is the sole or primary barrier, and will be subjected to constant or long-term hydraulic heads exceeding 300 mm (1 ft), subgrade surfaces consisting of gravel or granular soils may not be appropriate due to their large void contents and puncture potential. In these applications, the top 150 mm of the subgrade should possess a particle size distribution where at least 80% of the soil is finer than 0.25 mm (or #60 sieve) - unless the Sorbseal S2000 grade is being used (see below);
- For S2000 grade (with a composite woven/nonwoven carrier geotextile) in high hydraulic head applications:

### Subgrade materials recommended without further investigation are:

- Clays or clay-based mixes;
- Sandy clays (with > 20% fines);
- Silty or loamy clays (with > 20% fines) [fine grained soils should be placed at suitable moisture contents for construction operations and roll deployment - that provide adequate bearing capacity to deploy the rolls without disturbance of the subgrade - i.e no rutting or large deflections];
- Well graded sands and gravels (max < 32 mm, d<sub>60</sub> < 5 mm, d<sub>20</sub> < 0.15 mm). [these materials should bind and have good bearing capacity when compacted/rolled].

### Subgrade materials not recommended without further investigation:

- Single-sized and gap-graded sands and gravels of any size or description;
- Sands or soils that have low bearing capacity at the moisture contents during the construction/deployment operations i.e. materials that do not bind when rolled; will heave/shove under equipment or foot traffic during or after deployment);
- Subgrades that have a bony or porous appearance after compaction and rolling.

### Geosynthetic subgrades

When deploying Sorbseal over a geosynthetic material such as a geomembrane or geotextile, the surface should be firm and unyielding as per the requirements for earthen subgrades. The equipment used to deploy Sorbseal should be approved for use by the Design Engineer and/or the Supplier of the underlying geosynthetic material. Generally, the underlying geosynthetic and Sorbseal rolls will be deployed consecutively such that each layer is side-cast from equipment tracking over the earthen subgrade - unless specialised light rubber tyred dispensers are available and approved by the Design Engineer that allow direct trafficking over the geosynthetics.

### GCL placement

The Sorbseal roll wrapping should only be removed immediately prior to installation. On site, Sorbseal is unrolled along the prepared subgrade using the Spreader Bar assembly as shown in Figures 1 and 2 (overleaf).

**!** *Sorbseal should only be trafficked by light, low tyre pressure vehicles (no tracked vehicles).*

Rolls must be laid without folds on the subgrade with a standard overlap of 300 mm in both the longitudinal and transverse direction as detailed in Figures 3, 4 and 5. For longitudinal or edge overlaps, the blue coloured line on the underside of the panels can be used to ensure the correct overlap width. The edge of deployed or previously placed panels needs to coincide or match with the visible blue line on the roll being deployed.

The transverse or end overlaps need to be sealed using bentonite paste. The treatment of end (transverse) overlaps is detailed in Figures 6 and 7.

Rolls can be cut to length with a carpet/Stanley knife or Bosch cutter. When overlapping cut panels, bentonite paste will need to be applied as per the requirements for end (transverse) overlaps on the following page under Sorbseal Panel Overlaps.

No trafficking or walking should occur over the overlap region during installation. The overlap must also be free from folds and foreign matter e.g. soil. Any soil particles on the laps must be swept away carefully.

Overlaps should occur in the direction of ground slope in a similar manner to roof tiles.

## Damage to Sorbseal during installation

Where Sorbseal has been damaged during installation, covering with an overlapping piece of Sorbseal can repair such areas. The overlap should be at least 500 mm and should be completed in accordance with the Sorbseal Panel Overlaps section.

Figure 1 Sorbseal deployment using the standard Sorbseal Spreader Bar

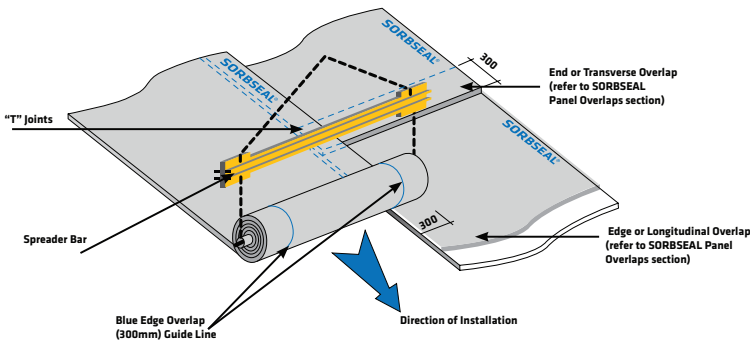
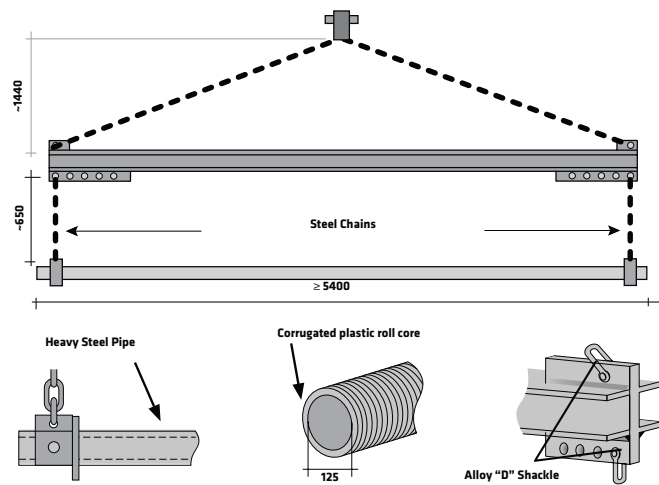

Figure 2 Sorbseal typical Spreader Bar assembly



**!** Refer to the Sorbseal Spreader Bar Safe Use Guide prior to using the lifting equipment and ensure that occupational health and safety requirements have been met and potential hazards eliminated.

## SORBSEAL PANEL OVERLAPS

### Longitudinal overlaps

The longitudinal overlap is where GCL rolls overlap along their length. The installation of a longitudinal overlap can be seen in Figure 1. The width of this overlap shall be a minimum of 300 mm which is indicated by a blue marker line printed on the bottom of the roll. The overlapping area has bentonite powder impregnated into the top nonwoven fibres of the GCL as seen in Figure 3 for grades S800 and S1000 and in Figure 4 for grades S2000 and S3000. When hydrated, the impregnated bentonite will swell into the fibre porespace to provide a sealed hydraulic barrier. An installed cross section can be seen in Figure 5.

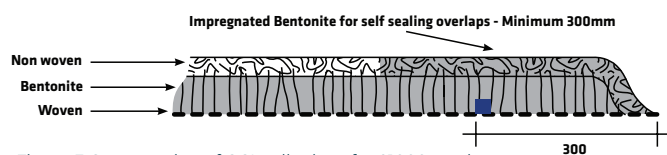

Figure 3 Cross section of GCL roll edges for S1000 grade

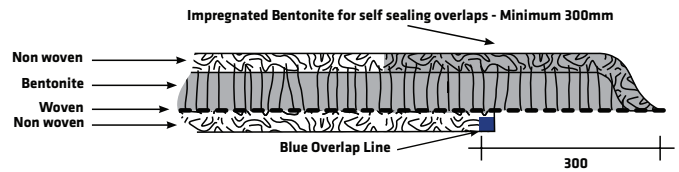

Figure 4 Cross section of GCL roll edges for S2000 grade

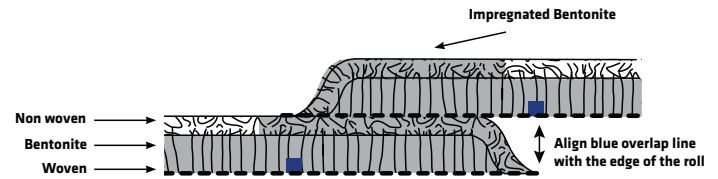

Figure 5 Longitudinal (or edge) overlap with self-sealing impregnated bentonite (S1000 shown)

### Transverse overlaps

Transverse overlaps occur at the end of rolls. The width of the GCL transverse overlap shall be a minimum of 300 mm. It is recommended that the topside of the underlying Sorbseal panel be marked as per Figure 6, as a reference point for paste placement. The top Sorbseal panel is then pulled back after marking.

All transverse/roll end overlaps should be sealed with bentonite paste. Geofabrics supplies HP paste which is an extensively tested sealing solution available in 20 L containers. As indicated in Figure 6, HP paste should be placed within the 300 mm overlap with a minimum width of 200 mm and a nominal thickness of 10 mm. The paste can be easily poured from the 20 L container and spread into place using a trowel or broom.

Approximately 10L or 1/2 of a container is used for each roll width at the transverse overlap. Once the paste is applied, the top panel is then rolled back into place and pressed down (Figure 6). Care should be taken to prevent folds or creases. The end overlap cross section for S1000 is shown in Figure 7. If an alternative method of end of roll overlap sealing is required, please consult your local Geofabrics office.

To ensure the integrity of the Sorbseal lining system it is essential that the treatment of end overlaps be carefully supervised. End overlaps in sumps or inverts are to be avoided.

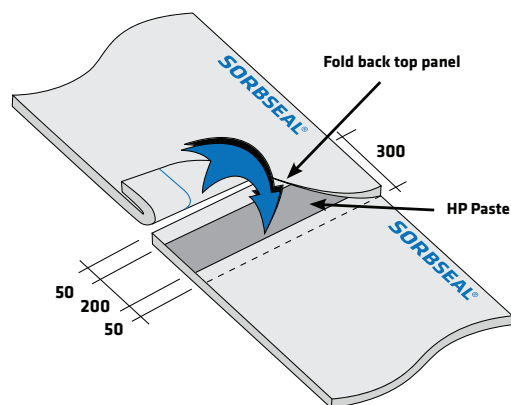

Figure 6 Transverse (end) overlap installation with applied HP Paste of minimum 200 mm width

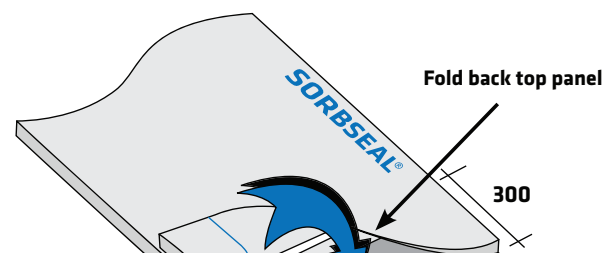

Figure 7 Transverse (end) overlap cross section (S1000 shown)

## Installation on slopes

The stability of lining system components on slopes should be assessed on a case-by-case basis. Geofabrics can assist in this respect upon request.

Sorbseal panels should be deployed in the direction of the slope as per Figure 8 and anchored at the crest of the slope (Figure 9). End (or transverse) overlaps on steep slopes should be avoided. If overlaps on slopes are unavoidable, please consult your local Geofabrics branch for information on custom extra-long GCL rolls.

Cover soil should be placed up the slope (starting at the toe). It must not be installed down the slope unless stability for this approach has been carefully investigated.

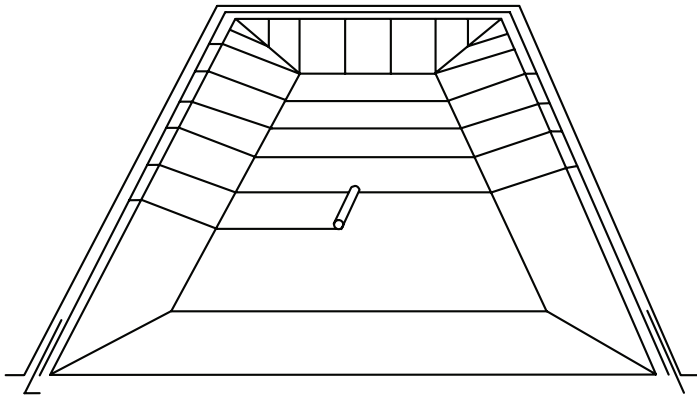

Figure 8 Recommended panel layout for sloping sites

## Anchor trenches

Anchor trench and slope stability considerations should be assessed by the Design Engineer.

As a general guide:

- An anchor trench should be used at the top of slopes steeper than 7H: 1V. (see Figure 9 for a typical anchor trench detail);
- The anchor trench should be constructed free of sharp edges or corners and maintained in a dry condition. The Sorbseal panels should be placed down the front face and along the base of the anchor trench. The base of the anchor trench should not contain large gravel or loose material and the trench backfill material should be compacted.

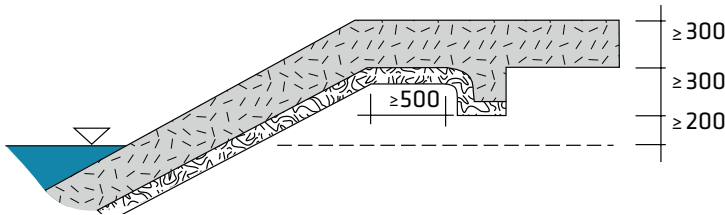

Figure 9 Typical anchor trench (all dimensions shown are typical values only)

## Connections & penetrations

Overlaps around connections, penetrations, and where panels have been cut should be carried out according to the principles outlined in Figures 5, 6 and 7. Most situations require site specific design input, however some commonly used details are shown below:

- Integration with thick compacted clay liners is shown in Figure 10;
- Cut-off trenches using Sorbseal GCL in cohesive soil are typically constructed as shown in Figure 11;
- Attachment and sealing against concrete structures, can be achieved according to Figures 12a and 12b. These typical connections are appropriate where the structure needs to be waterproofed to a height above and below the maximum containment level. Temporary fixing of the vertical Sorbseal panel to the structure (as shown) is required to allow the backfill placement;
- Penetrations such as pipe ducts are typically carried out according to Figure 13;
- Further connection methods and penetrations details can be discussed with Geofabrics.

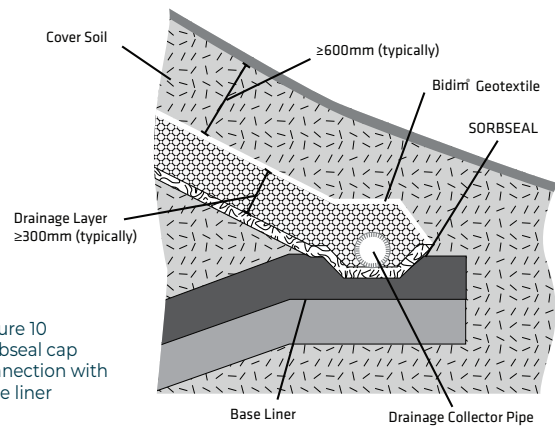

Figure 10 Sorbseal cap connection with base liner

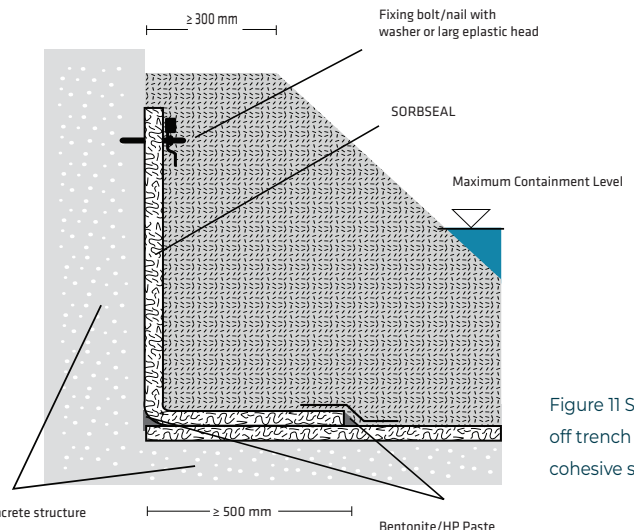
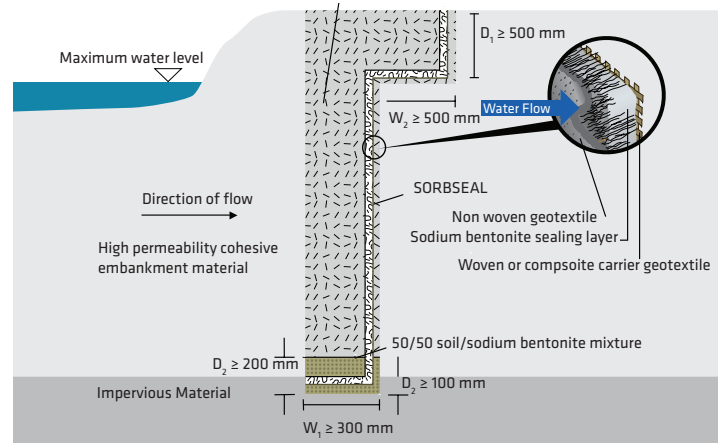

Figure 11 Sorbseal cut off trench detail for cohesive soils

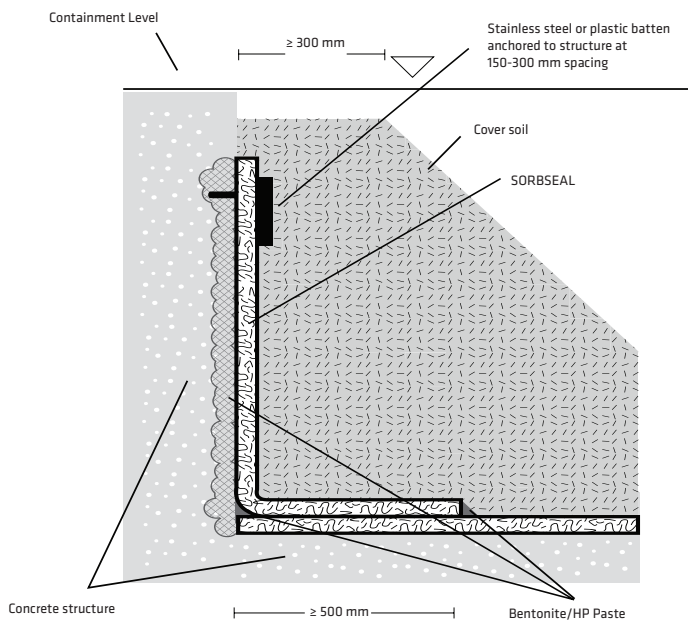

Figure 12b Typical connection to a concrete structure where the Sorbseal panel is required to extend below the maximum containment level

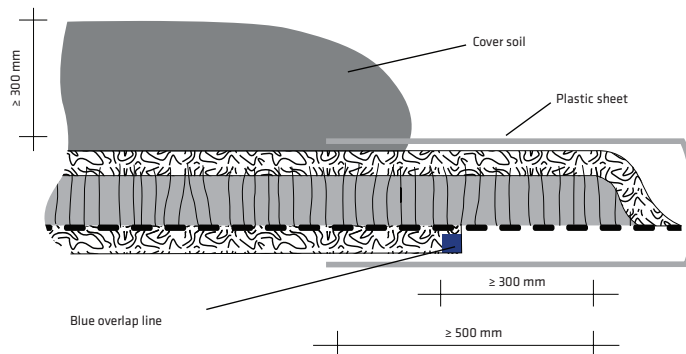

Figure 14 Covering Sorbseal with plastic sheet overnight or during wet weather

### Soil cover placement

A cover soil layer of at least 300 mm thick (approx. 6 kN/m<sup>2</sup> confining stress) should be placed and compacted over Sorbseal each working day immediately after the deployed panels have been inspected. In general, fine-grained cohesive material is recommended, although stones up to 32 mm are acceptable if the material is well graded ( $C_u > 5$ ) or stones up to 16 mm if single sized. Silty soils or organic material are not recommended without further stability analysis. Calcareous or limestone based cover soils should be evaluated prior to use.

Disturbance of the overlap area during placement (by means of vehicles spreading cover soil) must be avoided. It may be necessary to place the cover soil in this area manually or carefully using vertical placement by an excavator. The cover should not be pushed or graded in a direction that may cause the overlap to move (Figure 15).

Sorbseal may not be trafficked directly. The cover material should be pushed in front of the construction equipment thus creating a safe working platform. Overlaps should not be moved or squeezed during this process. In the case of an expected repeated dynamic load on Sorbseal, a sand layer of at least 300 mm should be laid first on the Sorbseal.

Generally, temporary access roads should not go over deployed panels. These areas should be sealed last to minimise traffic volume over deployed material. Where site traffic cannot be avoided e.g. the delivery of cover material by lorries) additional protection measures will be required. For temporary roads, a minimum roadbase thickness over Sorbseal of 600 mm is acceptable without any further analysis. Shallower coverage or alternative cover materials may be allowed after further analysis or field trials to assess the damage potential.

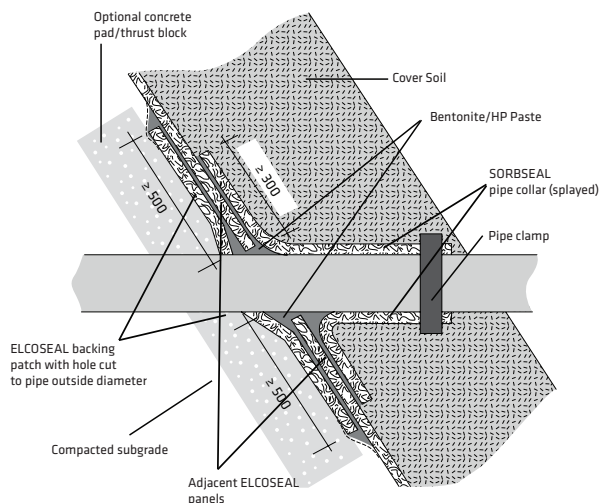

Figure 13 Typical pipe penetration detail

### Preparation for placing soil cover

Where the Sorbseal is not confined by the cover soil the same working day as deployment, a temporary layer of plastic should be laid to protect Sorbseal from prematurely hydrating (Figure 14).

If the deployed Sorbseal panels have hydrated (for example during a rainfall event) without confinement, special operating conditions may need to be imposed during cover soil placement. For example:

- If Sorbseal m.c.<sup>1</sup> <50%  
No special considerations;
- If Sorbseal 50% <m.c. <100%  
Avoid direct traffic (including foot traffic) on panels;
- If Sorbseal m.c. >100%  
Contact Geofabrics for advice.

1. m.c. = moisture content of the bentonite, % by weight

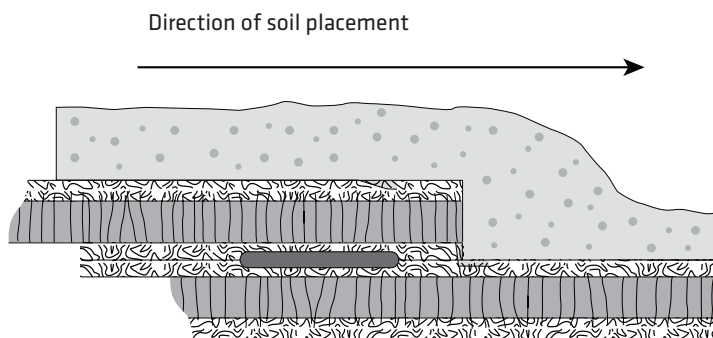

Figure 15 Cover soil placement

Visit [geofabrics.co](http://geofabrics.co) or call 1300 60 60 20

**GEOFABRICS**  
Sustainable solutions